

EX-6 series

HITACHI

EX

5500



HYDRAULIC EXCAVATOR

- **Model Code** : EX5500-6
- **Engine Gross Power** : 2 x 1 044 kW (2 x 1 400 HP)
- **Operating Weight** : Loading Shovel : 522 000 kg
Backhoe : 522 000 kg
- **Loading Shovel Bucket** : Heaped : 27.0 m³
- **Backhoe Bucket** : SAE, PSCA Heaped : 29.0 m³
CECE Heaped : 26.0 m³

Ultra Large Sized Production from the Hitachi Gigantic Excavators

The Hitachi Giants Yield Amazing
Mining Production...
Setting a New Standard





*Note: Photos in this brochure may include optional equipment.
They may also include custom-made options to meet specific user needs.*

SOLUTION GIANT

**Giant-Sized Productivity
Based on Hitachi's
Theory of Evolution.**

Each Hitachi generation listens to the needs of the work site and gives birth to an even-better new generation.



Bucket Passes to Dump Trucks

	HITACHI EH3500ACII	HITACHI EH4500-2	HITACHI EH5000
Nominal Payload	168 tonnes	254 tonnes	286 tonnes
Load Capacity (SAE 2:1 Heaped)	111 m ³	159 m ³	196 m ³
Loading Shovel 27.0 m ³	4	5	6 or 7
Backhoe 29.0 m ³	3 or 4	5	6



Powerful Engines— Ready for the task.

Time-proven Cummins diesel engines produce a total of 2 X 1 044 kW (2 X 1 400 HP) for handling the big excavation jobs.

- **2 X 1 044 kW (2 X 1 400 HP)**

Emission Control Engines— Helping to protect our environment.

Conform to U.S. EPA Tier II emission regulations.

Efficient E-P Control— Adjusts power output to the work being performed.

Hitachi's computer-aided Engine-Pump Control (E-P Control) coaxes optimum efficiency from the engines and hydraulic pumps. This innovative system senses load demand and controls engine and pump output for maximum operating efficiency.

Larger Bucket Provides High Work Capacity.

- Loading shovel bucket : **27.0 m³**
- Backhoe bucket : **29.0 m³**

Maximum Excavating Force.

- Loading shovel : **Arm crowding force : 1 570 kN (160 000 kgf)**
Breakout force : 1 570 kN (160 000 kgf)
- Backhoe : **Arm crowd force : 1 240 kN (126 000 kgf)**
Bucket digging force : 1 370 kN (140 000 kgf)

Large Bucket— Designed to enhance efficiency.

The large bucket has been shaped specifically to enhance scooping and loading operations. Its sharp tilt angle helps boost operating efficiency.

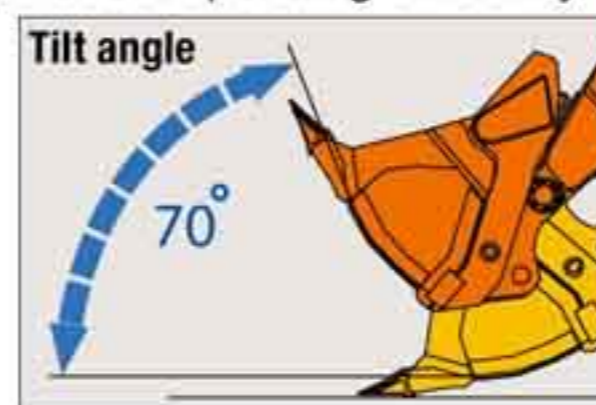

Productivity-Boosting Auto-Leveling Mechanism— One-lever leveling control.

This is another unique Hitachi function developed exclusively for more efficient leveling operations.

SOLUTION GIANT

More Than Durable — Just Plain Tough

Built-in toughness means the Hitachi will continue to get giant-sized jobs done fast.

Rigid Box Design— Resists bending and twisting forces.

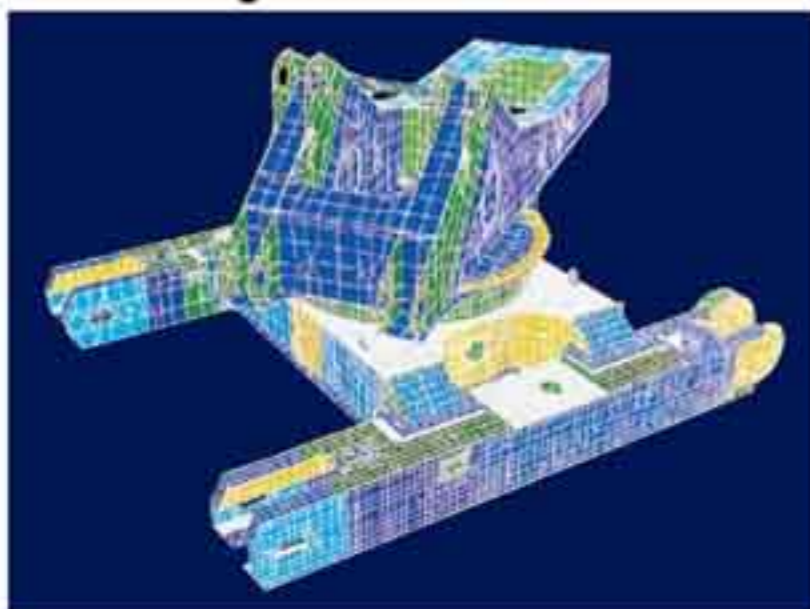

Computer-assisted analysis was used to check that the frame box can withstand heavy-duty excavation work.

Solid Cast Track Frame— More strength for this key area.

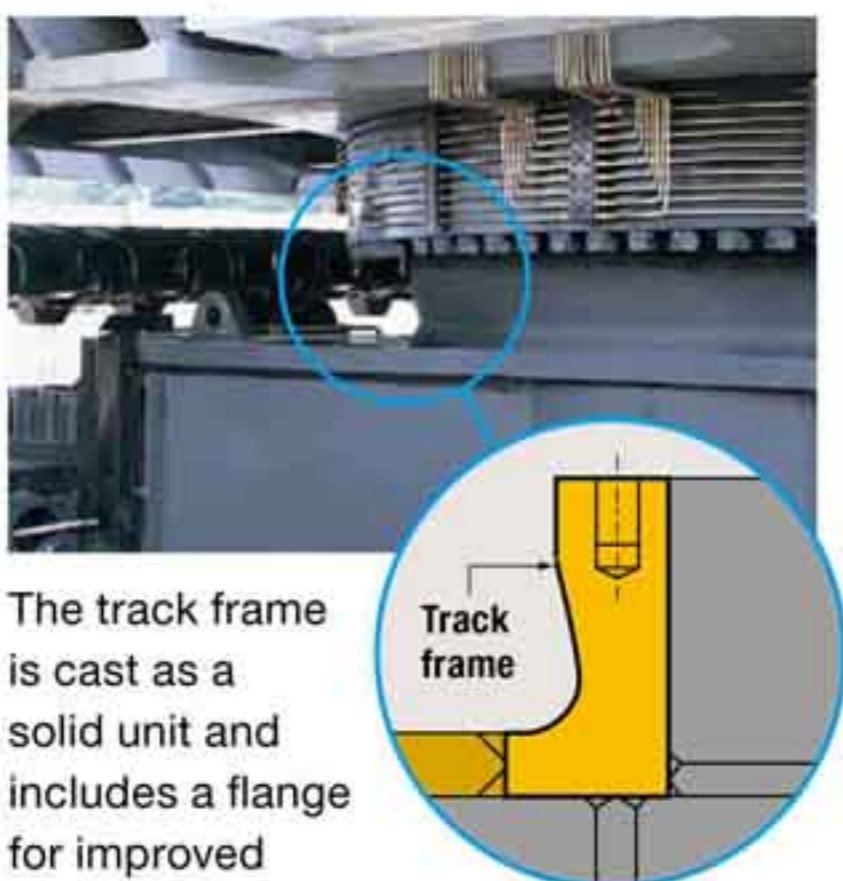

The track frame is cast as a solid unit and includes a flange for improved reliability. This non-welded design is used exclusively on large Hitachi models.

Strategically Positioned Oil Coolers— Helps keep oil temperatures



Two oil coolers are used for optimal cooling efficiency. They are positioned far from the engine radiator for even better cooling potential.

High-Mounted Compact Travel Motors and Optional Travel Motor Guard— Help to boost durability at rugged work sites.

This design helps protect the travel motors from damage by rocks.

Rugged Track Links— Shoes include roller guides for extended service life.

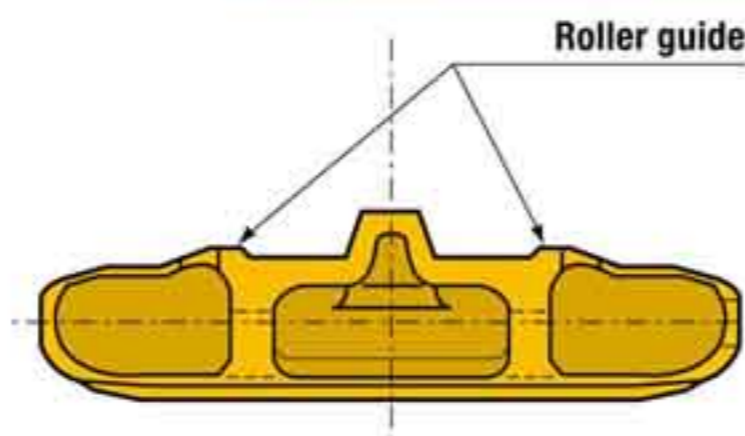

This design has proven itself on Hitachi's popular Giant EX Series. The roller guides have been added to help extend service life.

Constant Correct Track Tension— Nitrogen gas accumulators absorb abnormal track tension.

Helps prevent abnormal track tension from causing damage. Travel is automatically stopped if accumulator pressure exceeds a preset level.





EA5500

ACCESS LIGHTS

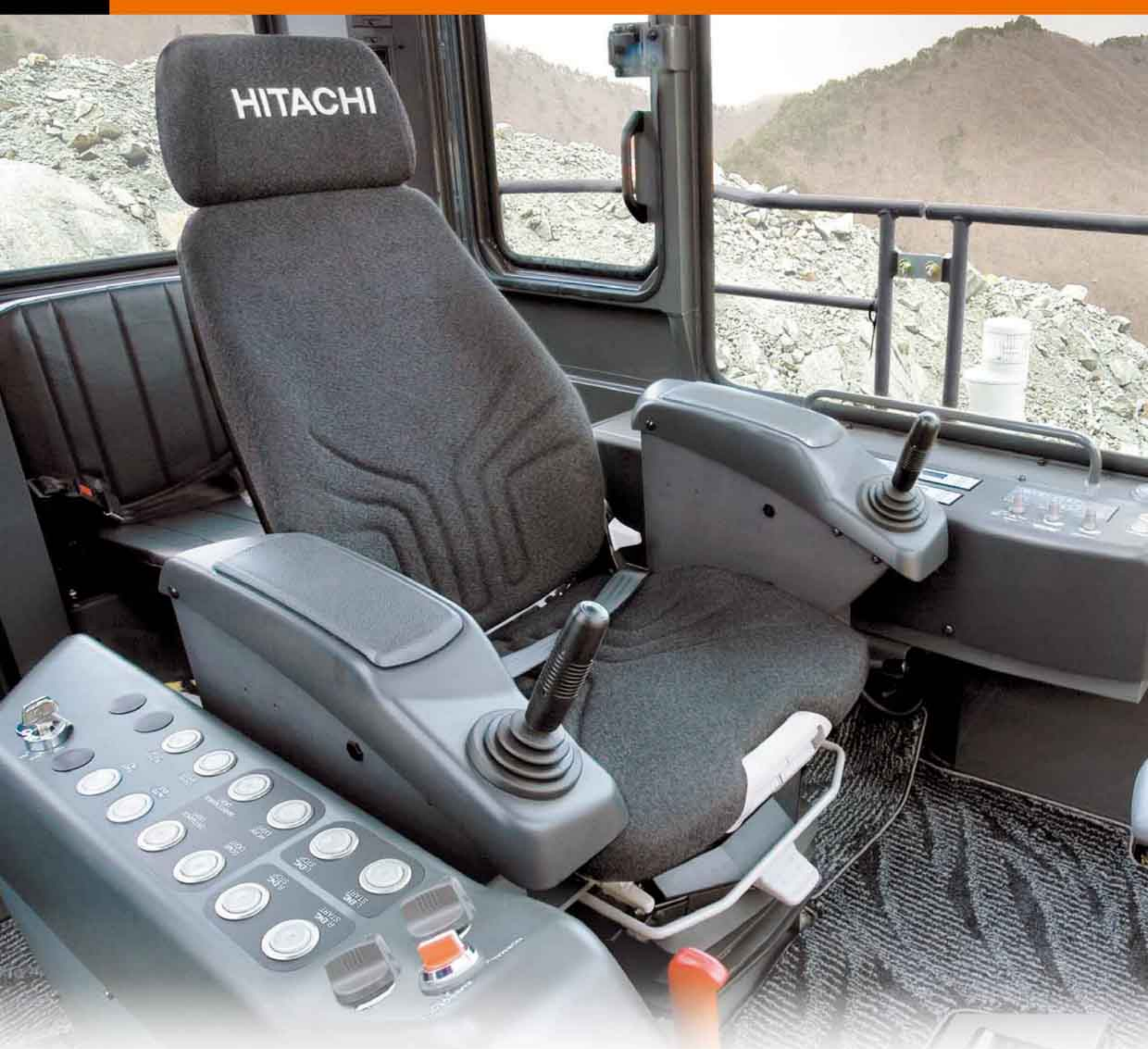

SOLUTION GIANT

Designed to Offer Comfort and Intelligence

Comfortable operator space and simplified maintenance, backed by Hitachi technologies and experience.

High Visibility 7.64 Meter Cab Height— Providing a clear view of the work area.

Gives the operator a clear view, even when a large 190 tonnes class dump truck is being loaded. This high height and forward-sloping cab provides a view that boosts productivity.

Rugged Comfortable Cab— Protects the operator from falling objects.

Fluid filled elastic mounts help absorb vibration to provide durability and a comfortable ride. The top guard, conforming to OPG* level II (ISO), is provided on the cab roof.

*Operator Protective Guard

Efficient Cab Layout— All controls within natural reach of operator.

The ergonomic layout of the cab means the operator will do less stretching and reaching when operating the controls. This adds up to less operator fatigue and greater operating efficiency.



Electric Joystick Levers— Provides pleasant control with less fatigue.

Electric joystick control levers have a feather-touch allowing long periods of effortless operation. Its stroke is much shorter than that of hydraulic control.

Air Suspension Seat with Auto Operator Weight Adjuster.

The operator seat cushion can automatically be adjusted according to the operator weight. This is convenient for a machine operated by two or more operators.

Adjustable Sliding Cockpit— Moves to the best position for the operator.

The operator can adjust the position of the levers and the seat to custom fit his size and operating style.



Constant-Cab-Comfort Air Conditioner— Keeps the cab pressurized to keep out dust while maintaining comfortable temperature.

Intelligent Multi-Display Monitor provides machine data and operating status at a glance.

The operator can monitor machine conditions and operating status with a 10.5-inch color LCD. The controller provides instant fault diagnosis through all sensors, displaying warnings and countermeasures if failure arises.

Major Functions:

- Multiple meters, and alert symbols indication
- Alert/failure status, and countermeasures indication
- Snap-shot function that stores operating data, including five-minute operating data immediately before alerting, and succeeding one-minute data (temperatures, pressures, and more)
- Setting oil change intervals with alerting

Much more functions are provided to ease maintenance and servicing.



* Illustration shows a sample of the Emergency Switch.

Outside Cameras (Optional)— Enhances operator's visibility.

The operator can monitor around the machine, using four optional cameras to eliminate blind spots.



SOLUTION GIANT

**Designed to be
Maintenable**

Carefully engineered
to allow full 24-hour
operation.



Easy Access and Maintenance—

Easy access speeds inspections and maintenance.

- 1 Diesel Engine x 2
- 2 Engine Radiator x 2
- 3 Pump Drive Unit x 2
- 4 Hydraulic Pump x 12
- 5 Engine-Pump Bulkhead x 2
- 6 Hydraulic Tank
- 7 Fuel Tank
- 8 Control Valve x 6
- 9 High-Pressure Strainer x 12
- 10 Hydraulic Oil Cooler x 2
- 11 Hydraulic Oil Cooling Fan Motor x 2
- 12 Lubricator
- 13 Swing Device x 4
- 14 Center Joint
- 15 Battery Unit
- 16 Cab
- 17 Air Filter (Outer / Inner) x 4
- 18 Muffler x 4
- 19 Folding Stairs
- 20 Fuel Cooler
- 21 Reserve Tank (Coolant) x 2
- 22 LTA Radiator x 2
- 23 Pump Transmission Oil Cooler x 2
- 24 Reserve Tank (Engine Oil) x 2
- 25 Fuel Filter (Water Separator) x 2
- 26 Ladder

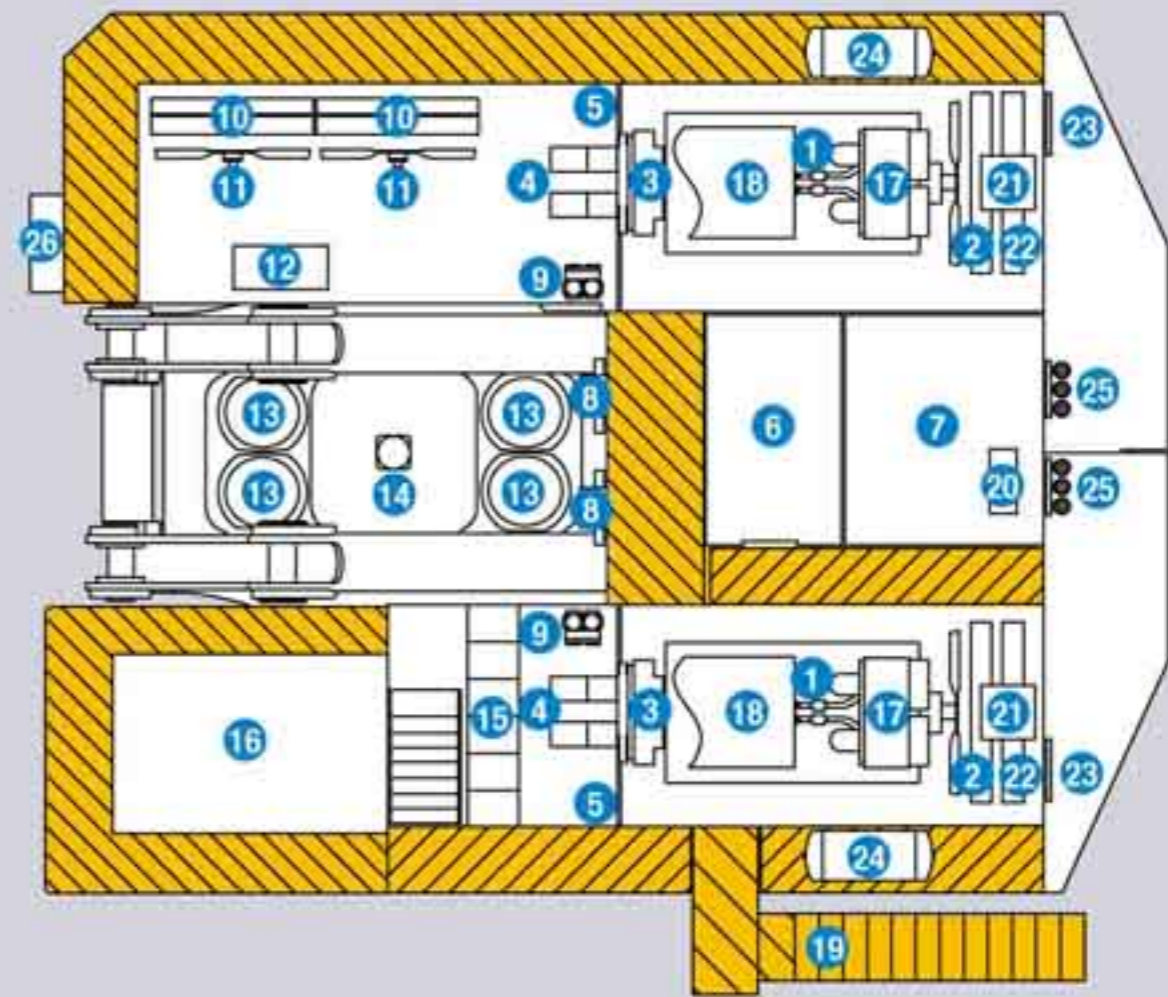

Counterweight with walkway— Easier access for maintenance.

A walkway around the entire counterweight provides easy access to key rear areas. This means faster and safer inspection and maintenance.

Folding Stairs with Wide Steps.



Folding stairs is designed for easy access to the machine for servicing and maintenance.

Wide-Open Service Area Provides the space needed for quick and easy inspection and maintenance.

This area is conveniently located at the center of the body and provides access to the engines as well as the hydraulic and electrical systems.

Auto Lubrication System Eliminates the need for manual lubrication.

This system automatically lubricates the front joint pins and swing circle. This eliminates cumbersome daily lubrication.

Auto Lubrication System— Eliminates the need for manual lubrication.

This system automatically lubricates the front joint pins and swing circle. This eliminates cumbersome daily lubrication.

Convenient Centralized Filter System— Designed to make filter inspection and maintenance easier.



Centralized position means that inspection and maintenance can be performed quickly and easily.

The Centralized Lubrication System: Fast Filling System



Low Maintenance Dust Ejector— Automatically expels dust from the air cleaner.

This is one less time-consuming task during routine maintenance.

Contamination sensor— Alerts the operator of excessive contaminants in the oil.

This system detects accumulated contaminants that could cause damage and alerts the operator before trouble occurs.

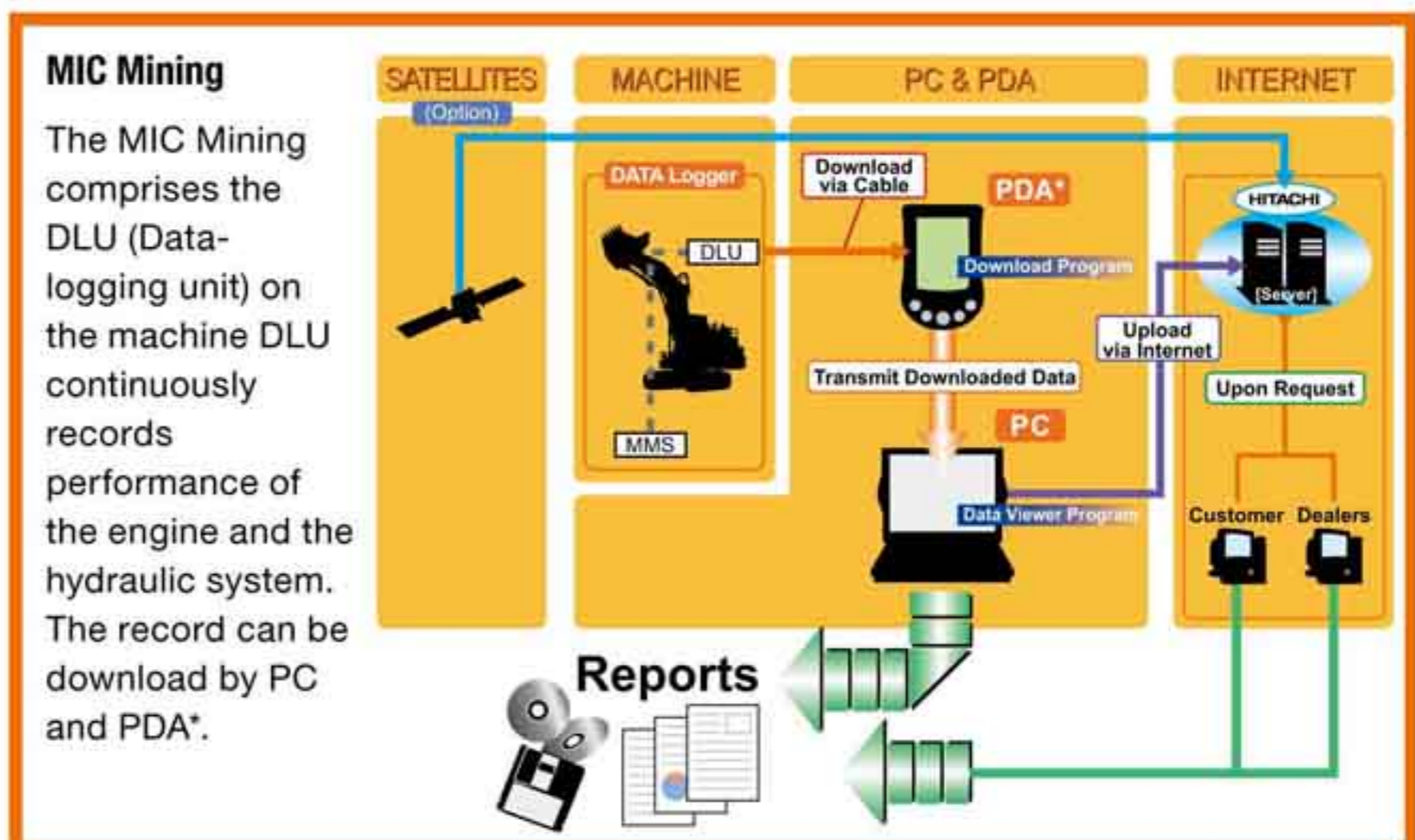

* Personal Digital Assistant

SPECIFICATIONS

WORKING RANGES

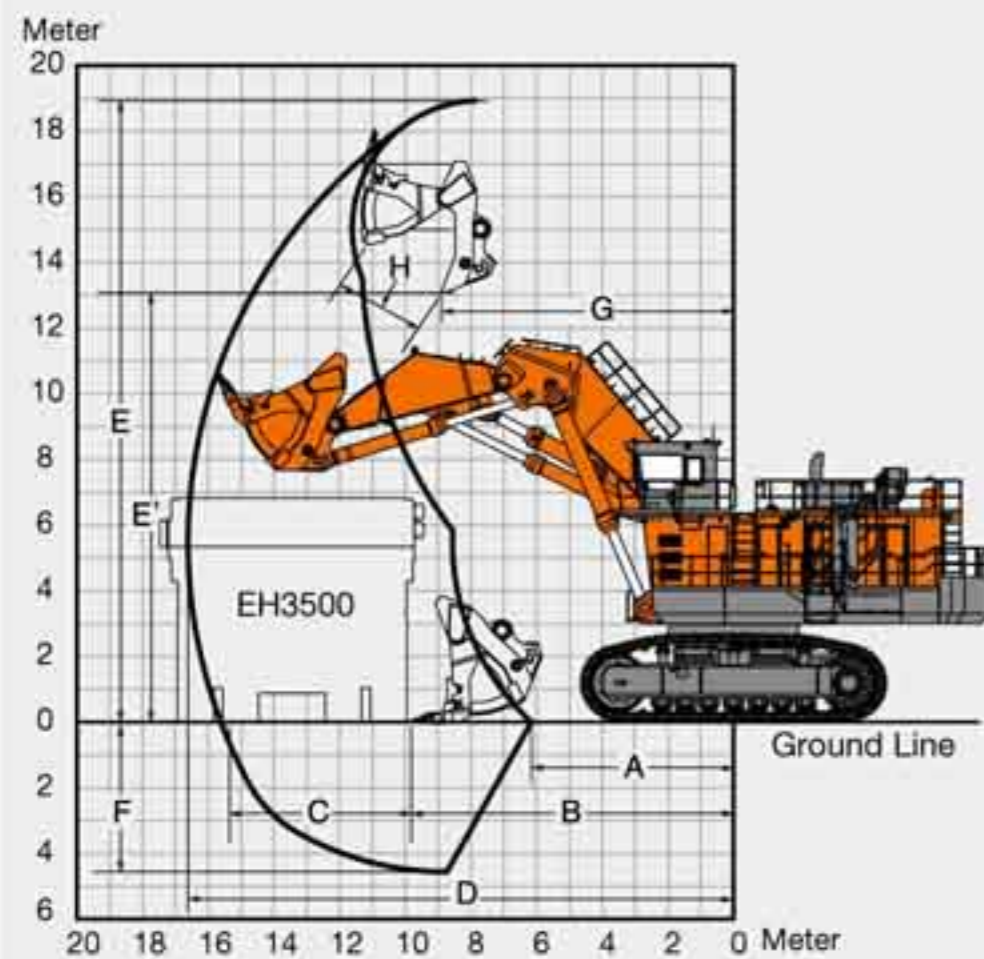

Loading Shovel

- A Min. digging distance
6 150 mm
- B Min. level crowding distance
9 800 mm
- C Level crowding distance
5 550 mm
- D Max. digging reach
16 600 mm
- E Max. cutting height
18 900 mm
- E' Max. dumping height
13 100 mm
- F Max. digging depth
4 550 mm
- G Working radius at max.
dumping height
8 900 mm
- H Max. bucket opening width
2 700 mm
- Arm crowding force
1 570 kN (160 000 kgf)
- Breakout force
1 570 kN (160 000 kgf)

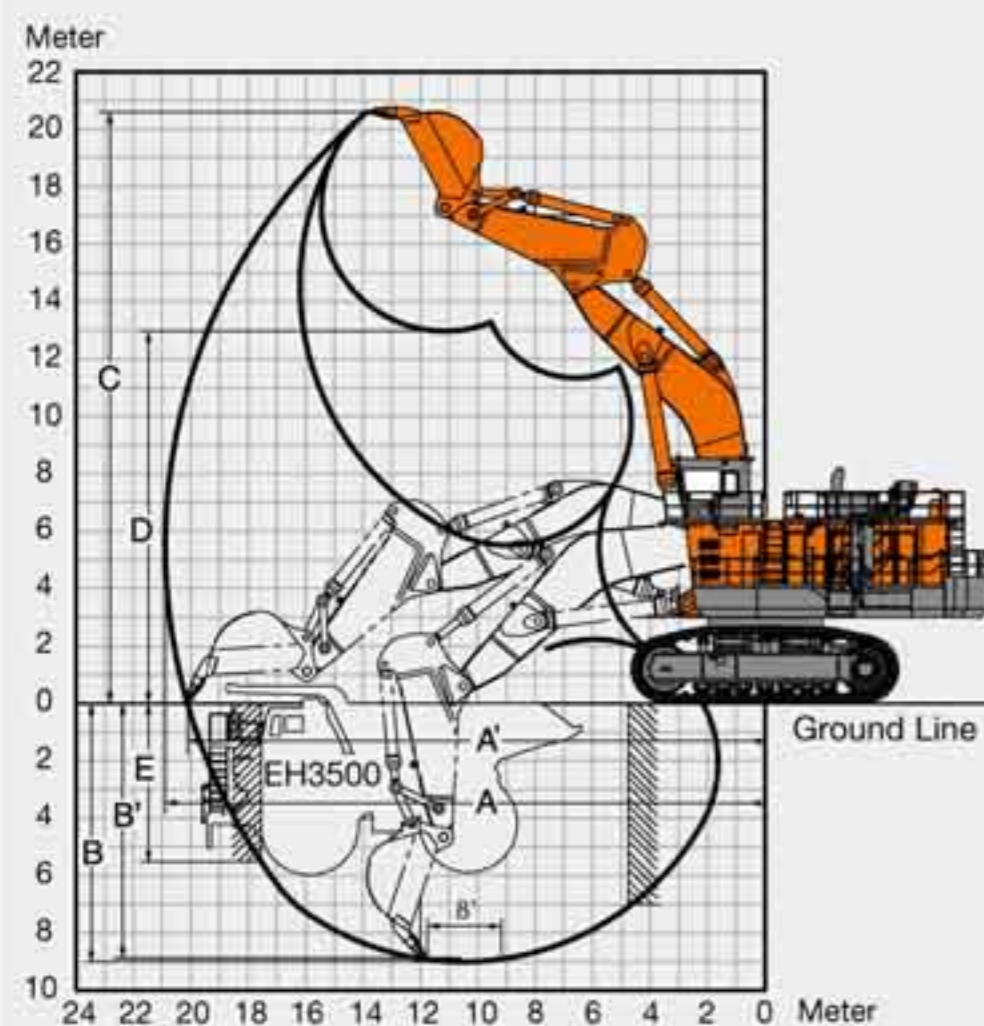

Backhoe

- 10.6 m BE-boom
- 5.3 m BE-arm
- A Max. digging reach
20 900 mm
- A' Max. digging reach (on ground)
20 100 mm
- B Max. digging depth
9 000 mm
- B' Max. digging depth (8' level)
8 900 mm
- C Max. cutting height
20 600 mm
- D Max. dumping height
13 000 mm
- E Max. vertical wall
5 500 mm
- Bucket digging force
ISO
1 370 kN (140 000 kgf)
- SAE: PCSA
1 310 kN (134 000 kgf)
- Arm crowd force
ISO
1 240 kN (126 000 kgf)
- SAE: PCSA
1 230 kN (125 000 kgf)

DIMENSIONS

Unit: mm

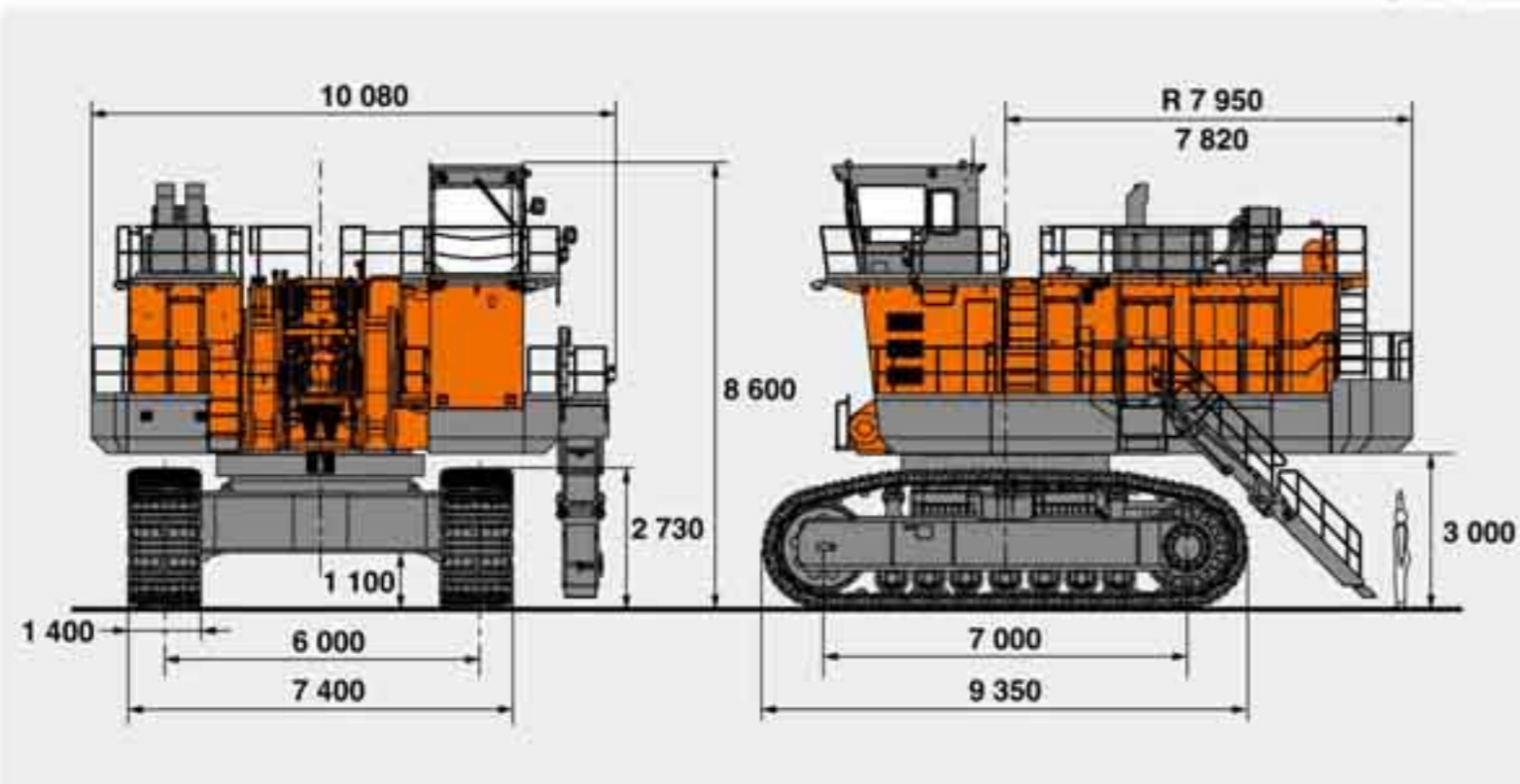

ENGINE

- Model..... Cummins QSKTA50-CE
- Rated power
SAE J1995, gross ... 2 x 1 044 kW (2 x 1 400 HP)
at 1 800 min⁻¹ (rpm)
- Net..... 2 x 994 kW (2 x 1 333 HP)
at 1 800 min⁻¹ (rpm)
- Piston displacement.... 2 x 50 L
- Fuel tank capacity 11 300 L

HYDRAULIC SYSTEM

- Main pumps..... 8 variable-displacement, axial piston pumps for front attachment and travel
- Pressure setting 29.4 MPa (300 kgf/cm²)
- Max. oil flow 8 x 375 L/min
- Swing pump..... 4 variable-displacement, axis piston pumps for swinging
- Pressure setting 29.4 MPa (300 kgf/cm²)
- Max. oil flow 4 x 425 L/min

UPPERSTRUCTURE

- Swing speed 3.3 min⁻¹ (rpm)

UNDERCARRIAGE

- Travel speeds..... High: 0 to 2.3 km/h
Low : 0 to 1.6 km/h
- Maximum traction force... 2 230 kN (227 000 kgf)
- Grade ability 60 % (30 degree) max.

WEIGHTS AND GROUND PRESSURE

Loading Shovel

Equipped with 27.0 m³ (heaped) bottom dump bucket

Shoe width	Operating weight	Ground pressure
1 400 mm	522 000 kg	232 kPa (2.37 kgf/cm ²)

Backhoe

Equipped with 10.6 m BE-boom, 5.3 m BE-arm and 29.0 m³ (SAE, PCSA heaped) bucket

Shoe width	Operating weight	Ground pressure
1 400 mm	522 000 kg	232 kPa (2.37 kgf/cm ²)

ATTACHMENTS

Loading Shovel

Bucket Capacity (heaped)

27.0 m³ : Materials density 1 800 kg/m³

Backhoe

Bucket Capacity (SAE, PCSA heaped)

29.0 m³ : Materials density 1 800 kg/m³

The number of wear plates and their installation positions on the bucket of loading shovel or backhoe vary depending on applications at job site. The installation of wear plates is indispensable. Consult your nearest Hitachi or Hitachi dealer for details.

These specifications are subject to change without notice.

Illustrations and photos show the standard models, and may or may not include optional equipment, accessories, and all standard equipment with some differences in color and features.

Before use, read and understand the Operator's Manual for proper operation.